

# COMPRESSORI LINEARI A MEMBRANA

LINEAR MEMBRANE BLOWERS

DBMW60

## MODELLO DBMW60



I compressori lineari a membrana della serie DB, sono silenziosi, robusti ed affidabili. Non richiedono lubrificazione e garantiscono una portata costante per la durata prestabilita delle membrane. Scocca in alluminio per un migliore raffreddamento. Ogni modello viene fornito con la protezione termica incorporata.

Linear membrane blowers of DB series are silent, robust and reliable. Oil free operation is granted as well as a steady flow for the foreseen lifetime of the membranes. The aluminium body provides a better cooling efficiency. Each model is equipped with built in thermal protection



Dimensioni / Dimensions = mm

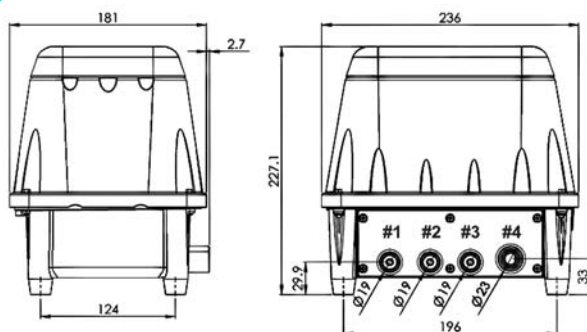

#1, #2, #3:  
sono collegate  
a valvola a solenoide/  
outlet with Solenoid Valve

4#: **sempre aperta/**  
normal open



**Emmecom s.r.l.**  
Via P. Nenni, 70  
20093 Cologno Monzese (MI)  
Tel. +39 02 25 33 300 (r.a.)  
Fax +39 02 27 307 908  
[www.emmecomsrl.com](http://www.emmecomsrl.com)  
[sales@emmecomsrl.com](mailto:sales@emmecomsrl.com)

Model Modello n.	Voltage (AC) Voltaggio (CA)	Frequency Frequenza (Hz)	Rated Pressure Pressione nominale (mbar)	Airflow Portata (l/min.)	Watt	Ampere	Max Vacuum Max Aspirazione (mbar)	Noise Rumorosità (dBA)	Weight Peso (Kg)
DBMW60	220~240	50	+150	66	61	0.6	-	<47	8.7

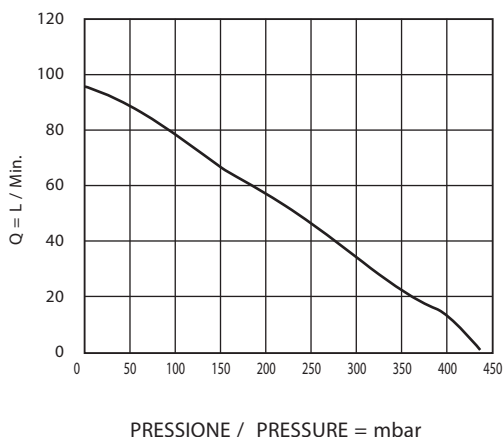

I valori di portata e pressione si intendono per il convogliamento dell'aria avente in aspirazione temperatura di 15°, densità di 1,23 kg/m<sup>3</sup> e pressione a 1.013 mbar. La tolleranza di queste curve si intende del ±5%. I dati sopraindicati possono essere variati senza preavviso.

The characteristic data given here refer to the handling of gas with inlet temperature of 15° C, normal density of 1,23 kg/m<sup>3</sup> and absolute pressure of 1.013 mbar. Tolerance of ±5%. The data may change without any notification.

a i r m o v i n g