

# POMPA PER VUOTO AD ANELLO LIQUIDO

LIQUID RING  
VACUUM PUMP

AL1200A

## MODELLO AL1200A



La pompa per vuoto ad anello liquido modello AL1200A è del tipo monostadio con valvola, in esecuzione ad asse nudo. Compatta, versatile nelle prestazioni, raggiunge 33mbar ass., adatta ad aspirare vapori e gas con tracce di liquidi, non necessita di lubrificazione, manutenzione contenuta. Disponibile in versione standard oppure in acciaio inox AISI 316 (parti umide).

The liquid ring vacuum pump model AL1200A is single stage type fitted with vary port valve, bareshaft version. Compact, flexible in performance, achieves 33 mbar abs., suitable to suck vapors and gas with liquid carry over, oil free operation, limited maintenance required. Available in standard version or in ss AISI 316 (wetted parts).

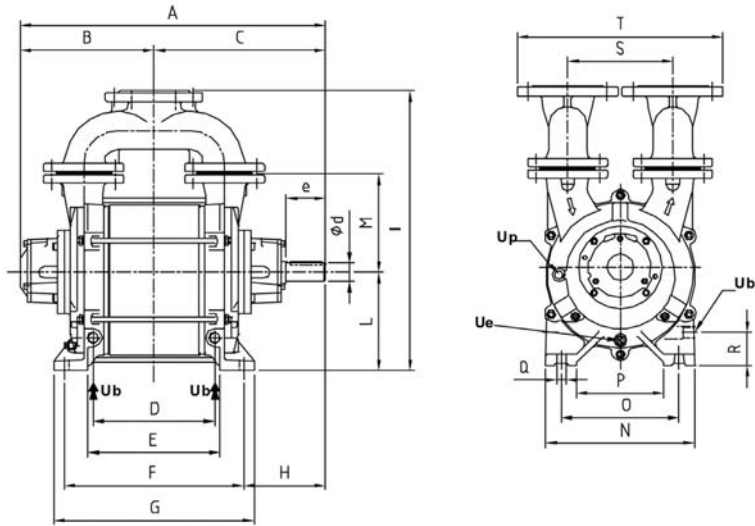

**Emmecom s.r.l.**  
Via P. Nenni, 70  
20093 Cologno Monzese (MI)  
Tel. +39 02 25 33 300 (r.a.)  
Fax +39 02 27 307 908  
www.emmecomsrl.com  
sales@emmecomsrl.com



	A	B	C	D	E	F	G	H	I	L	M	N	O	P	Q	R	S	T	Peso totale - Kg Total Weight - Kg
AL1200A	1007	437	570	390	420	550	620	295	850	335	305	480	378	280	22	110	340	590	510

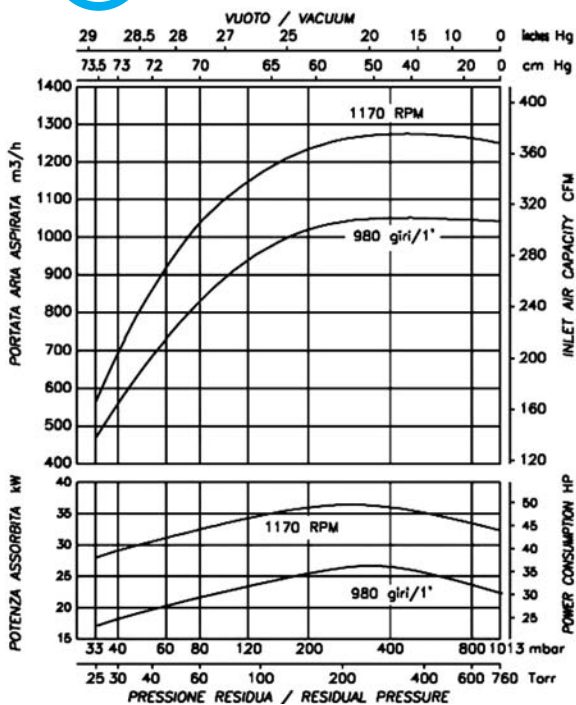

	FLANGE	UNI PN 10			ANSI 150		
		DN	X	Y	Z	X	Y
AL1200A	125	210	254	18	215,9	254	22,2

Ub	1 <sup>o</sup> .1/2 GAS M/NPT F	Attacco per liquido di esercizio Service liquid connection
Ue	1/2" NPT	Drenaggio pompa Pump drain
Up	1/2" NPT	Rompivuoto Relief valve
d	60	Albero - Shaft
e	140	Albero - Shaft
f	18	Albero - Shaft
g	64	Albero - Shaft

I valori di portata sono riferiti ad aria secca, alla temperatura di 20°C, alla pressione atmosferica di mandata (1013 mbar), e all'impiego di acqua alla temperatura di 15°C. Tolleranza di prestazione ± 10%. Nell'esecuzione in inox la portata diminuisce del 10%. I dati sopraindicati possono essere variati senza preavviso.

The given capacity values are referred to dry air at the temperature of 20°C, atmospheric discharge pressure (1013 mbar), and of supply of service water at 15°C temperature. Performance tolerance ± 10%. Stainless steel construction is 10% less performing. The data may change without any notice.

a i r m o v i n g