

I Application

The RV pump is the best solution for the transfer of liquid/solid blended products or medium viscosity products that cannot be pumped with an ordinary centrifugal pump.

Due to the helicoidal shape of the impeller, the transfer of the product is gentle and without clogging.

It is ideal for applications of the transfer of semi-finished products, product remains, waste, etc. in the food-processing industry and vanishes, glues, wastewaters in the chemical industry.

In comparison with the the RV_XX range, the RV_XXR pumps are provided with a bearing support in the lantern for work with viscous products and for applications provoking an increased axial stress.

I Operating principle

Due to the helical shape of the impeller, the pump lets solid particles pass without destroying their structure and the flow is optimized to avoid its obstruction.

I Design and features

Close-coupled design.

Helicoidal impeller.

Pump casing with drain port.

Pump casing with eccentric volute.

High efficiency (65 - 70%), low power consumption.

Motor: IEC B35 1500 rpm.

Mechanical seal: EN 12756 (DIN 24960 L1K).

Connections: DIN 11851.

Bearing support integrated into the lantern (RV-80R and RV-100R).

Maximum particle size: \varnothing 75mm.

I Materials

Parts in contact with the product	AISI 316L
Lantern	AISI 316L
Other stainless steel parts	AISI 304
Bearing supports (RV_XXR)	GG 25
Gaskets	EPDM according to FDA 177.2600
Mechanical seal	SiC/SiC/EPDM
Internal surface finish	Electropolished
External surface finish	Electropolished

I Options

Connections: SMS, Clamp, Macon, Garolla, FIL, RJT, flanges, DIN, etc.

CE control panel with 10 m cable and plug.

St.St. trolley.

Remote control.

Motor shroud.

Motor with a frequency converter.



I Technical specifications

Max. flow	180 m ³ /h	793 US GPM
Max. differential head	22 mwc	72 ft
Max. working pressure	8 bar	116 PSI
Max. working temperature	-10 °C to +120 °C (EPDM)	14 °F to 248 °F
	+140 °C (SIP, máx. 30 min)	284 °F
Max. speed	1800 rpm	

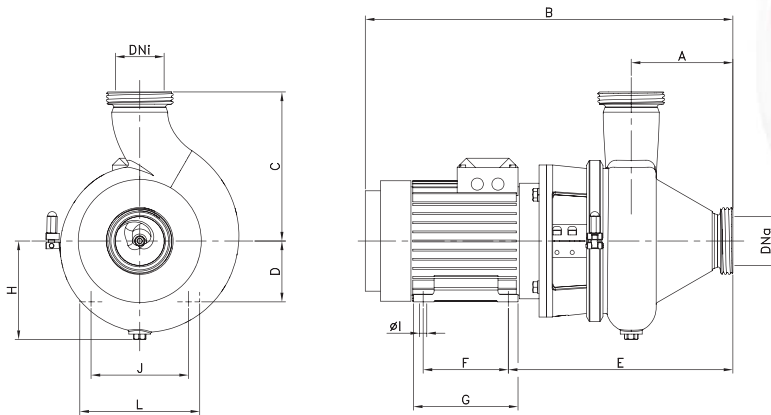

TYPE	solids Ø [mm]	Power [kW] (IEC)	Speed [rpm]	DNa DNi	A	B	C	D	E	F	G	H	ØI	J	L
RV-65	45	0,75 (80)	1500	65	120	483	215	80	283	100	125	130	10	125	160
RV-80	60	2,2 (100) 4 (112)		80	167	632	245	100	369	140	172	163	12	160	197
RV-100	75	4 (112)		100	189	671	280	112	406	140	172	186	12	190	220

Dimensions in mm

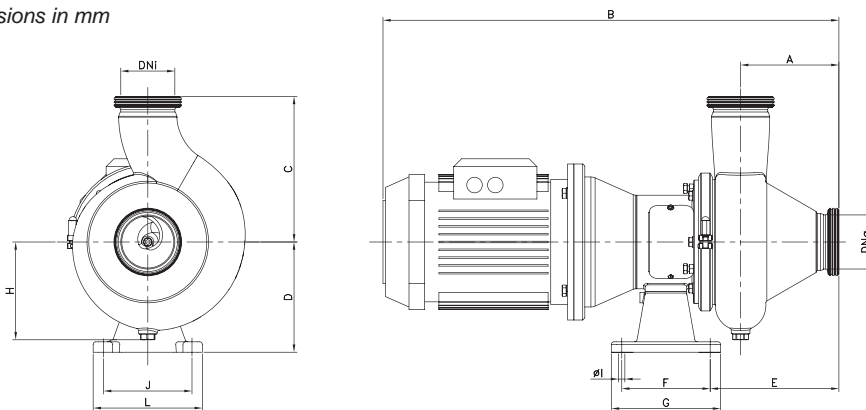

TYPE	solids Ø [mm]	Power [kW] (IEC)	Speed [rpm]	DNa DNi	A	B	C	D	E	F	G	H	ØI	J	L
RV-80R	60	2,2 (100)	1500	80	167	765	245	212	225,5	170	210	165	13	170	210
		4 (112)			167	795	245	212	225,5	170	210	165	13	170	210
RV-100R	75	4 (112)		100	189	817	280	212	247,5	170	210	188	13	170	210
		5,5 (132) 7,5 (132)			189	875	280	212	247,5	170	210	188	13	170	210

Dimensions in mm



The information contained in this brochure is for guidance only. We reserve the right to modify any material or feature without notice in advance. For further information, please, consult our web page. www.inoxpa.com



FT.RV.2.EN-0408